

Identification of Specimens

OB_TC_R010 rev. 002

Confidential



**Hans Tommerup Knudsen
Arno van Wingerde
Modris Megnis**

<http://www.ecn.nl/optimat/cgi-optimat/docbase-upload.cgi?cq=1&num=10091&rev=0>





Change record

Issue/revision	date	pages	Summary of changes
1	14-02-03	Na	na
2		9	Optimat formatting, compacted first two pages into one; Changed D01 to D12, geometry of Risø dogbone has minimum width of 25 mm instead of 20 mm.

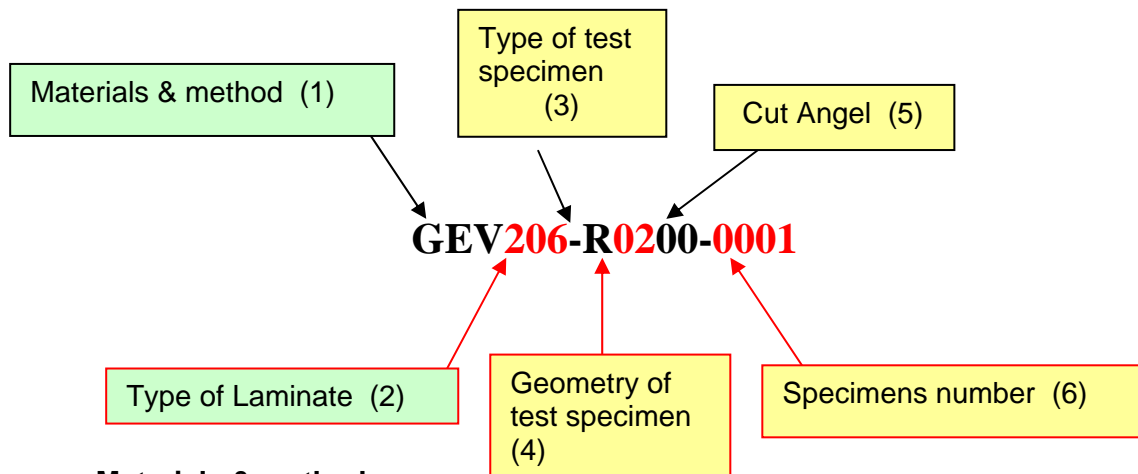

1) Materials & method

G: Glasfibre **E:** Epoxy **V:** Vacuuminjection

2) Type of Laminate

Definition of Laminate		
Laminate Code	Laminate Lay Up	Materials
GEV206	$[0^\circ]_4$	Combi1250
GEV207	$[\pm 45^\circ/0^\circ]_3 / \pm 45^\circ$	Combi1250 & Biaxial 806
GEV208	$[+45^\circ/-45^\circ/-45^\circ/+45^\circ]$	Combi1250
GEV209	$[0^\circ]_{57}$	Combi 1250
GEV210	$[\pm 45^\circ/0^\circ]_{33} / \pm 45^\circ$	Combi1250 & Biaxial 806
GEV211	$[0^\circ]_2$	Combi 1250
GEV212	$[0^\circ]_3$	Combi 1250
GEV213	$[0^\circ]_7$	Combi 1250
GEV214		
GEV215		

3) Type of Test specimen

R: Rectangular
D: Dogbone
I : ISO or ASTM
S: Special
T: Thick geometry

4) Geometry of specimen

See appendix A

5) Cut angel

The two digit indicate the relative angel between the 0° fiber direction and the 0° direction of test specimen.

6) Specimen number

The last four digits indicate the consecutive numbers for the specific laminate and geometry.



Appendix A

Geometry of Specimens

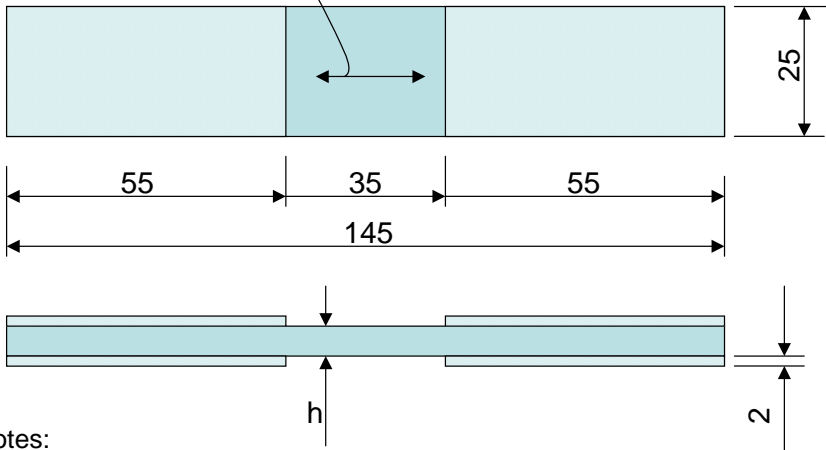
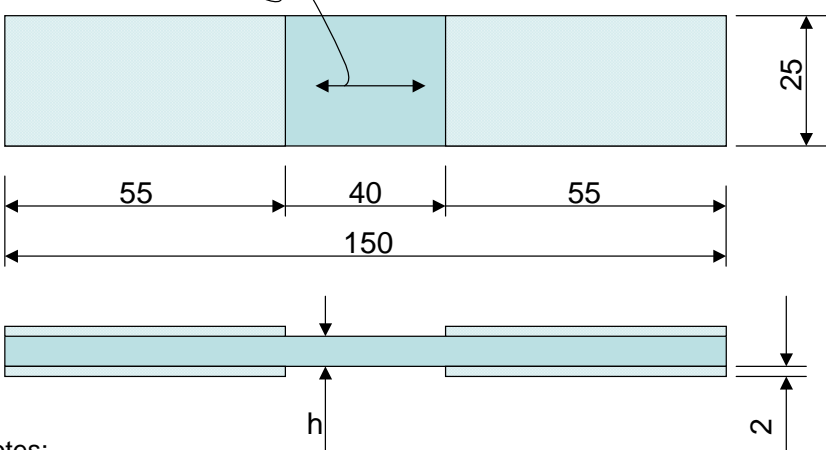
Specimen Code	Geometry of Specimen
R03	<p>Principal direction (0°)</p>  <p>Notes:</p>
R04	<p>Principal direction (0°)</p>  <p>Notes:</p>

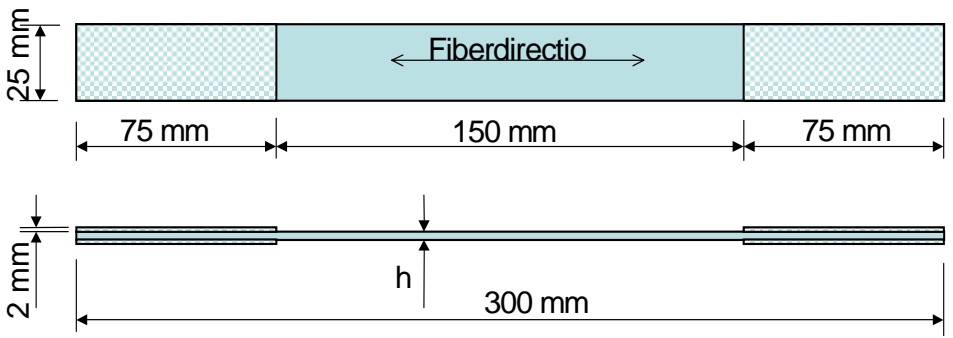
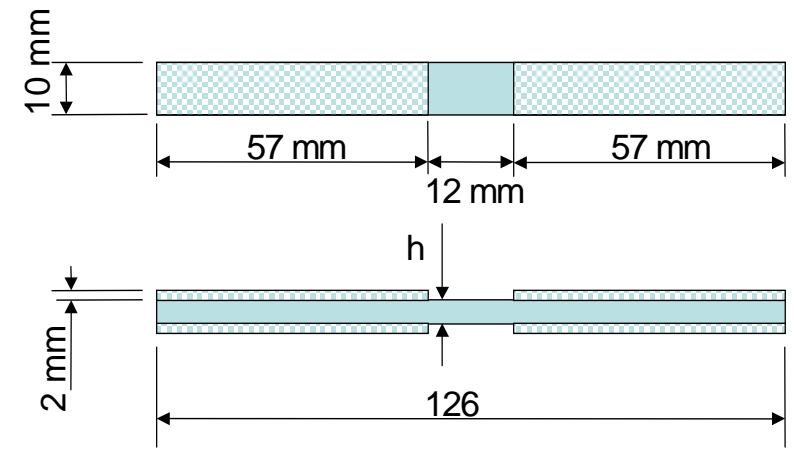
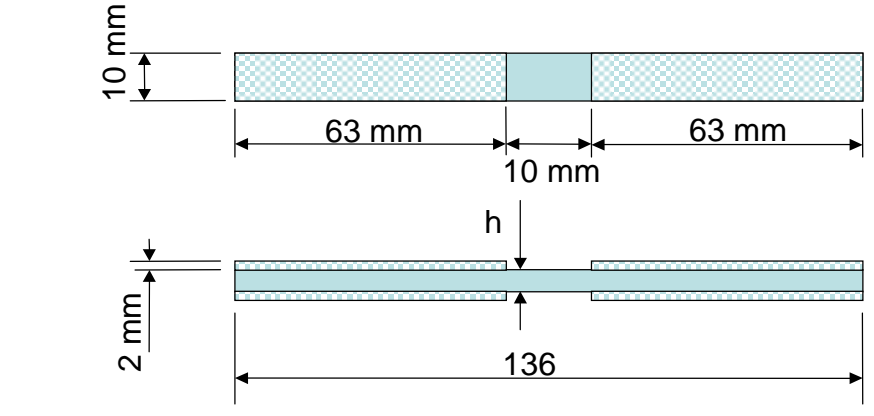
Specimen Code	Geometry of Specimen
I01	 <p> The diagram shows the geometry of specimen I01. The top view is a rectangle with a total length of 300 mm and a height of 25 mm. It is divided into three sections: two end sections of 75 mm each and a central section of 150 mm. The central section is labeled 'Fiberdirectio' with arrows pointing left and right. The side view shows a total length of 300 mm and a thickness of 2 mm. The height of the specimen is denoted as h. </p>
I02 (RISØ)	 <p> The diagram shows the geometry of specimen I02. The top view is a rectangle with a total length of 126 mm and a height of 10 mm. It is divided into three sections: two end sections of 57 mm each and a central section of 12 mm. The side view shows a total length of 126 mm and a thickness of 2 mm. The height of the specimen is denoted as h. </p>
I03 (TUD)	 <p> The diagram shows the geometry of specimen I03. The top view is a rectangle with a total length of 136 mm and a height of 10 mm. It is divided into three sections: two end sections of 63 mm each and a central section of 10 mm. The side view shows a total length of 136 mm and a thickness of 2 mm. The height of the specimen is denoted as h. </p>

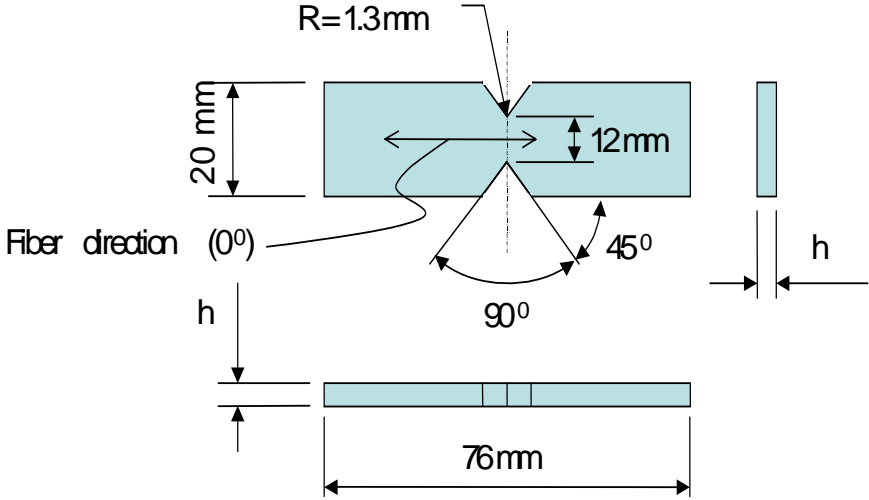
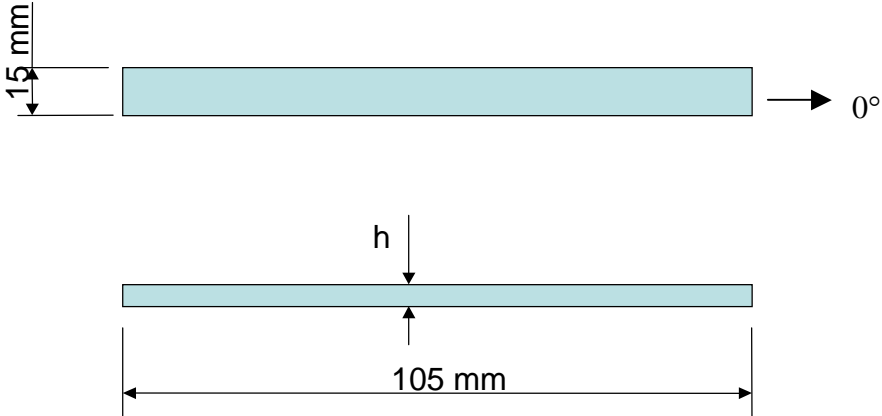
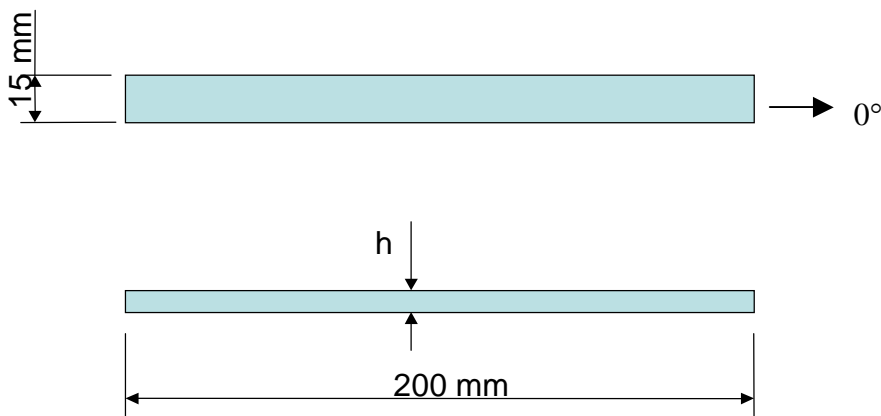
Specimen Code	Geometry of Specimen
I04	 <p>Diagram illustrating the geometry of specimen I04. The specimen is a rectangular plate with a width of 20 mm and a length of 76 mm. The thickness is denoted as h. The fiber direction is 0°. The specimen features a central notch with a radius $R=1.3\text{mm}$ and a depth of 12 mm. The notch is oriented at a 45° angle relative to the fiber direction, and the total angle of the notch is 90°. A side view shows the thickness h.</p>
I05	 <p>Diagram illustrating the geometry of specimen I05. The specimen is a rectangular plate with a width of 15 mm and a length of 105 mm. The thickness is denoted as h. The fiber direction is 0°.</p>
I06	 <p>Diagram illustrating the geometry of specimen I06. The specimen is a rectangular plate with a width of 15 mm and a length of 200 mm. The thickness is denoted as h. The fiber direction is 0°.</p>

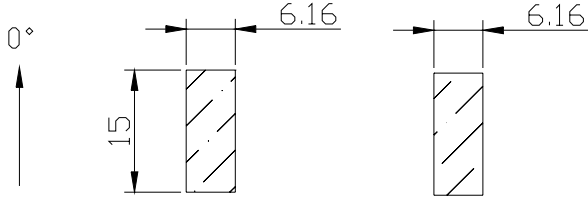
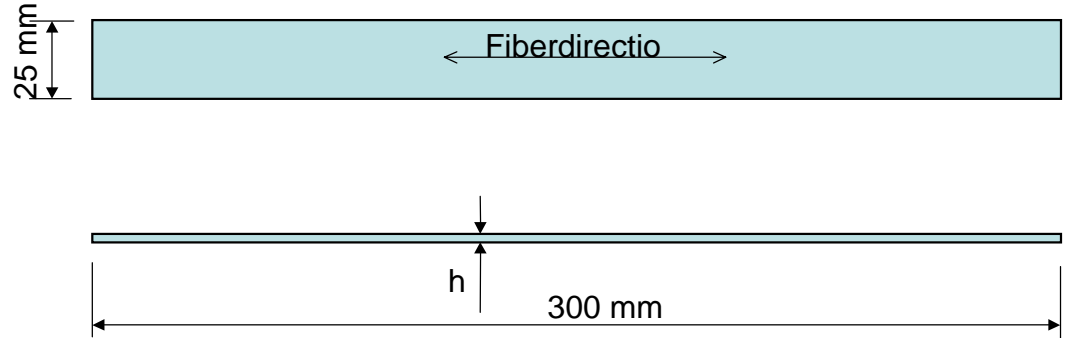
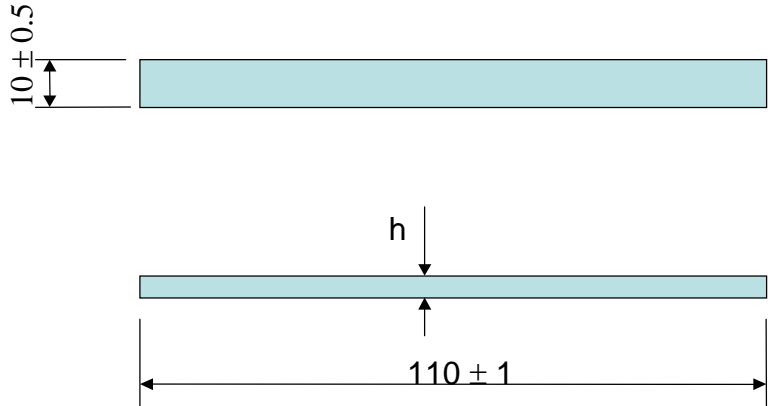
Specimen Code	Geometry of Specimen
I07	
I11	
I12	

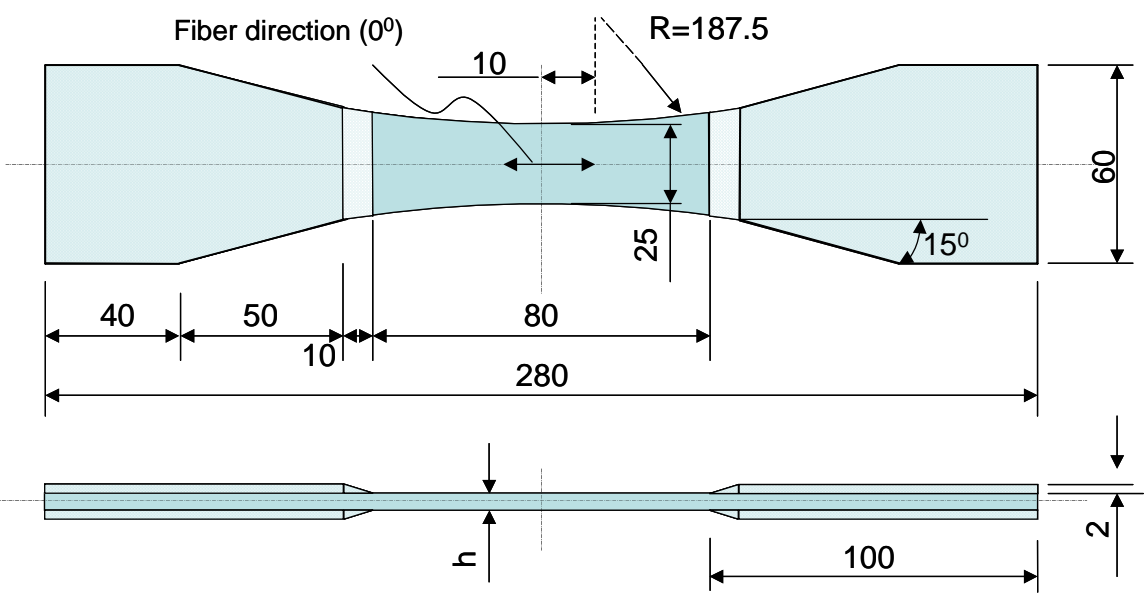
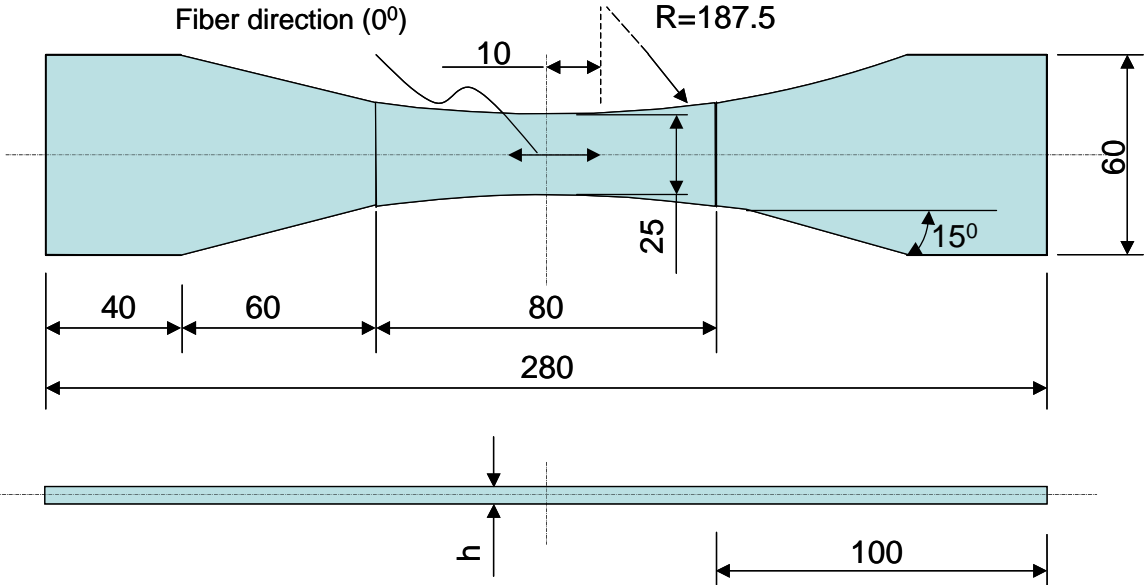
Specimen Code	Geometry of Specimen
D02	 <p> Fiber direction (0°) $R=187.5$ 10 25 15° 40 50 10 80 280 r 100 2 </p>
D12	 <p> Fiber direction (0°) $R=187.5$ 10 25 15° 40 60 80 280 r 100 </p>

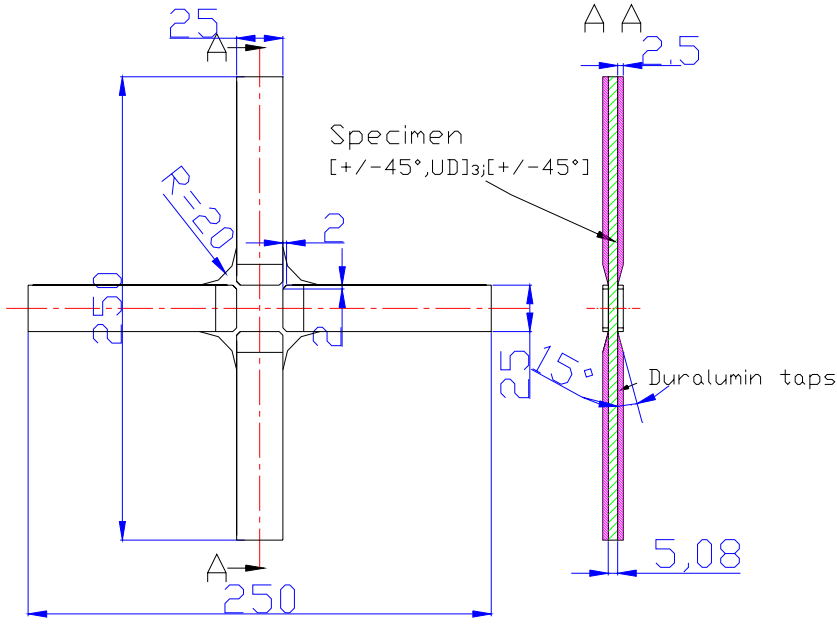
Specimen Code	Geometry of Specimen
S01 Geometry 1	 <p>The technical drawing illustrates the geometry of specimen S01. It consists of a front view and a side view. The front view shows a central vertical slot with a width of 25 mm and a depth of 250 mm. The slot is flanked by two horizontal sections, each 250 mm wide and 25 mm high. The corners of these horizontal sections are rounded with a radius of R=20 mm. The side view shows a vertical specimen with a diameter of 2.5 mm. The specimen is made of Duralumin taps and is tapered at a 15-degree angle. The total length of the specimen is 5.08 mm. The material specification is given as Specimen $[+/-45^\circ, UD]_3; [+/-45^\circ]$. Section lines A-A are indicated at the top and bottom of the specimen.</p>



S01
Geometry 2

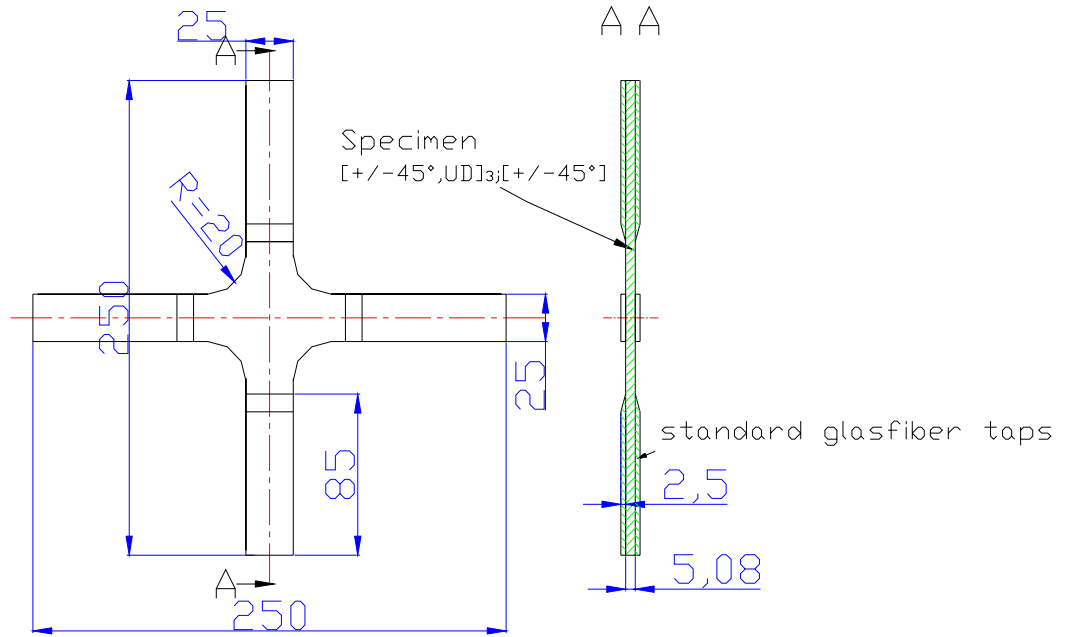

Specimen
Code

Geometry of Specimen

S01
Geometry 3

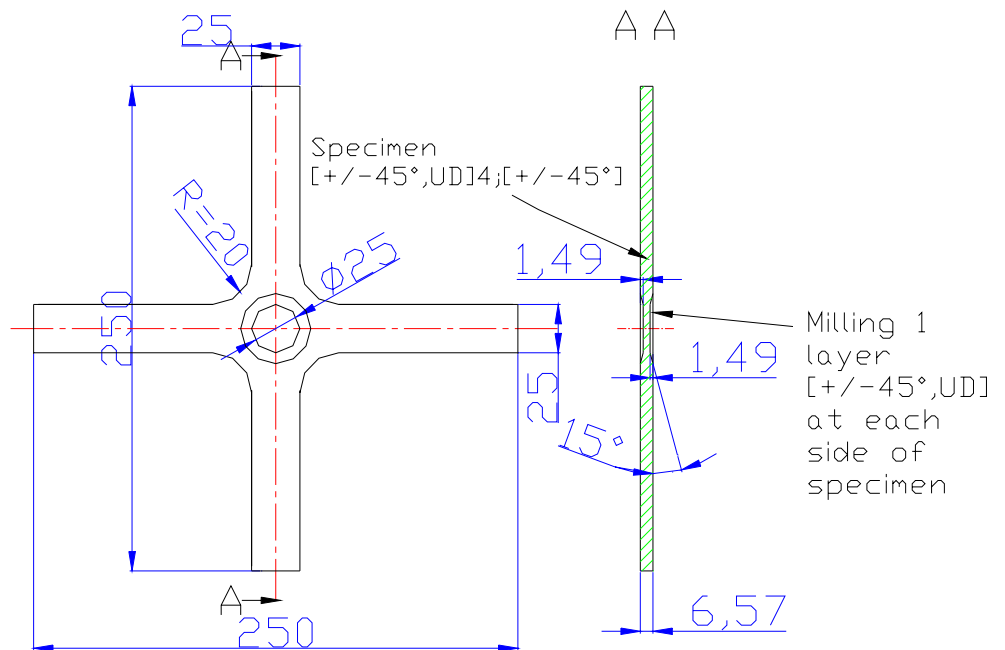



S01

Geometry 5

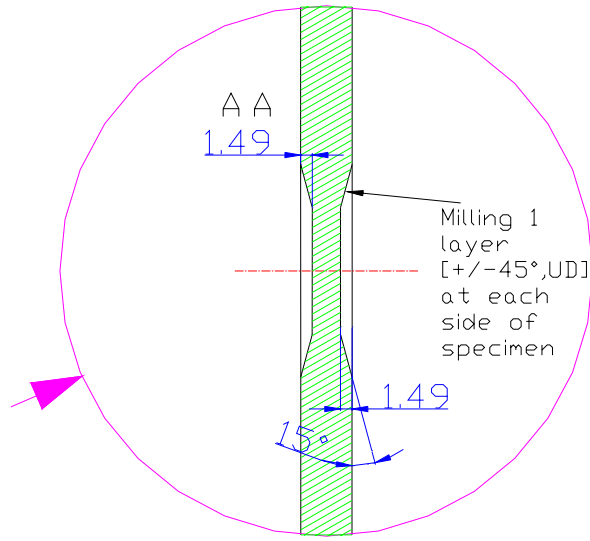

Specimen Code

Geometry of Specimen

S01

Geometry 7

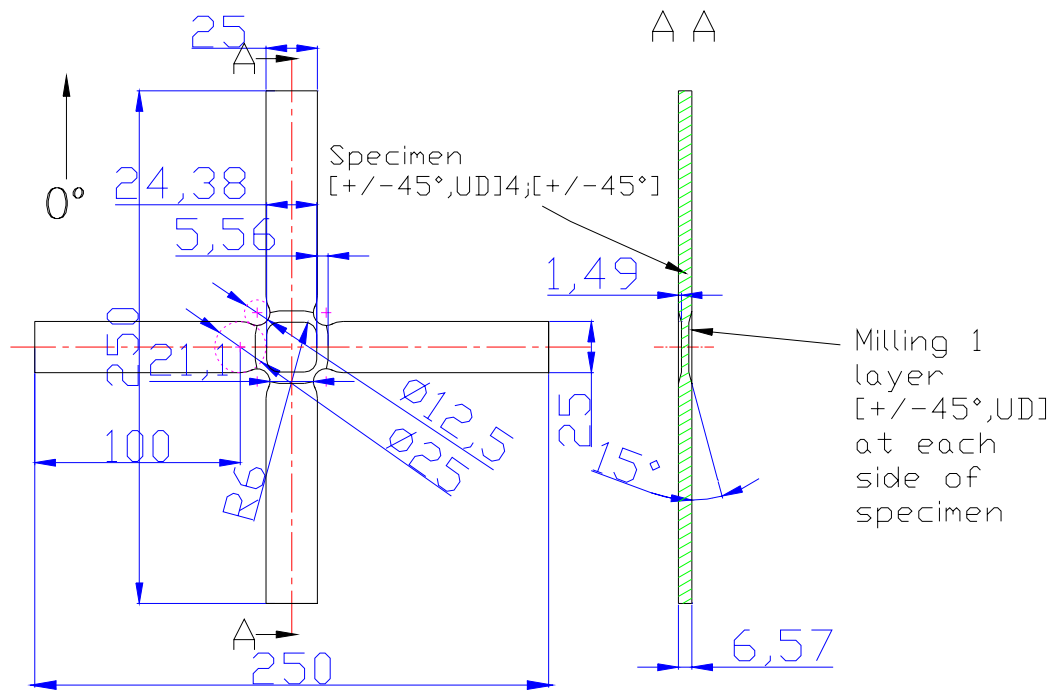

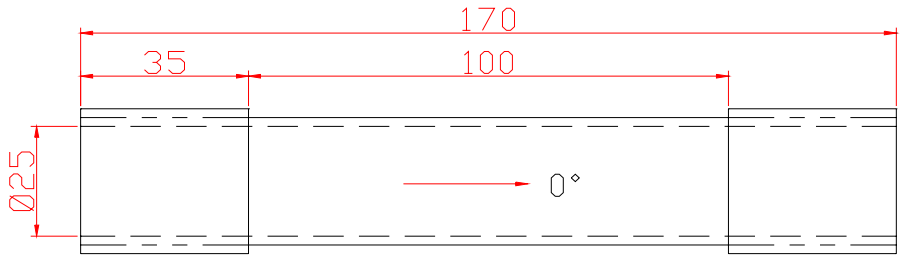
Specimen Code	Geometry of Specimen
S02	 <p>The diagram shows a cylindrical specimen with a diameter of 25. The total length is 170. A central section of length 100 is marked with a 0° angle. A distance of 35 is indicated from the left end to the start of the 100-length section.</p>